



This spring-loaded lock design provides tamper-resistant lock-up of ventilator. A key slot in the housing requires a special key to operate the lock. One end of the key is removable only in the locked position, while the opposite end of the key is removable in either the locked or unlocked position. This key also acts as a handle when operating the vent. A 90° movement of the operating key locks or unlocks the vent.

Custodial locks unlock by turning counter-clockwise. Special clockwise-turning models are also available upon request. Rear mounted models have concealed screws, while front-mounted models have in-line elongated holes for mounting. Up to 300 lbs. of forced entry resistance per locking point is achievable with this product — see table for further details.

WARRANTY:

Protected under the terms of the Truth Warranty for Window and Door Manufacturers and Authorized Distributors. Refer to Truth's Terms and Conditions for further details.

MATERIAL: High-pressure die cast zinc housing, zinc-plated steel pawl, stainless steel spiral pin, zinc plated steel operating key, and stainless steel keepers.

FINISH: Electrostatically applied, durable coatings that provide excellent resistance to chipping, scratching and corrosion while maintaining color stability for years in direct sunlight. Please refer to Truth's Color Chart for examples of Truth's most popular finish options. Truth also offers a wide range of decorative "plated" finishes - contact Truth for additional information on availability of these finishes on specific product lines.

ORDERING INFORMATION:

1. Choose lock style desired (specify by part number).
2. Specify finish number.
3. Select mounting hardware (sold separately):
 - a. Specify keeper number.
 - b. Optional:
 - (1) #20408 - Rubber-cork adhesive backed gasket (1 per lock).
 - (1) #20313 - Key (removable handle).

**RECOMMENDED SCREWS:**

Types of screws required determined by material of profile used. Refer to drawings for complete information on screw type and quantity needed (sold separately). For additional information regarding screw selection - see Truth Tips and refer to Tech Note #11.

TRUTH TIPS:

1. Keeper #30238 is recommended because the lead-in provided helps insure smooth lock operation.
2. Keeper #20303 and #20404 must be backed up against a PVC wall to prevent failure of the keeper.
3. For accurate hardware placement in vinyl or metal applications, pre-drilling of the window profile is recommended.
4. For vinyl window applications, mounting screws should pass through two PVC walls, or one PVC wall and one insert wall. For this reason, it may be necessary to use a longer screw than is recommended.
5. Truth recommends that stainless steel screws be used to fasten stainless steel components to the window. When selecting mounting screws for Truth hardware, coating compatibility is one of the most important criteria. For best corrosion resistance the coating on the screws should be the same as the coating on the hardware.

6. For metal window profiles, Truth recommends machine screws. However, in most applications, sheet metal screws will provide adequate holding power.

INCLUDE TRUTH SPECS ON YOUR NEXT WINDOW PROJECT

Custodial locks must be provided which allow tamper-resistant key/handle operation. The locks must hold securely up to 300 lbs. of force per lock for negative air pressure and forced entry resistance.

Window locks shall be of concealed pawl type design which allows operation with a removable key/handle. The lock must be constructed of a high pressure zinc housing, zinc-plated steel pawl and stainless steel spiral pin. Keepers used with this lock will be stainless steel.

Window locks shall be 28 series Custodial, as manufactured by Truth Hardware, Owatonna, MN.

28 KEY OPERATED CUSTODIAL LOCK (REMOVEABLE HANDLE)

FIG. 1 CUSTODIAL LOCK (key operated)

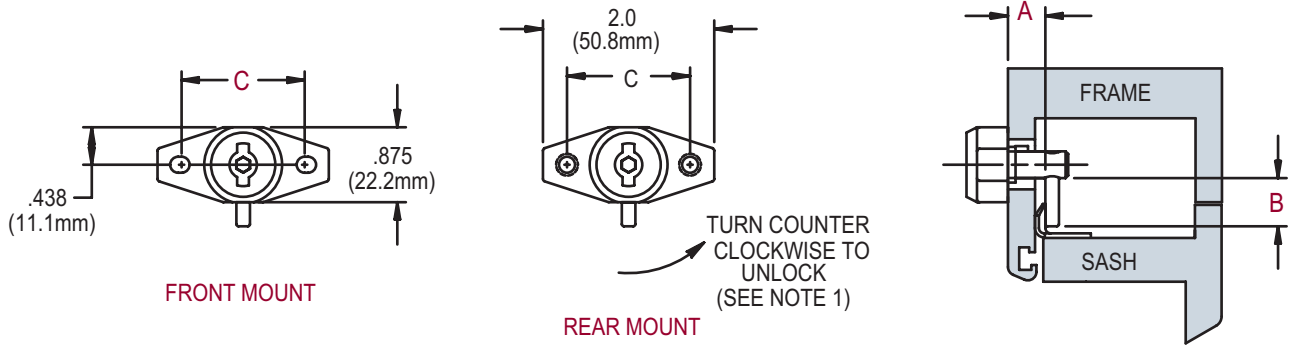

NOTE:
1. SPECIAL LOCKS ARE AVAILABLE THAT UNLOCK IN A CLOCKWISE ROTATION; SPECIFY OPPOSITE HAND.

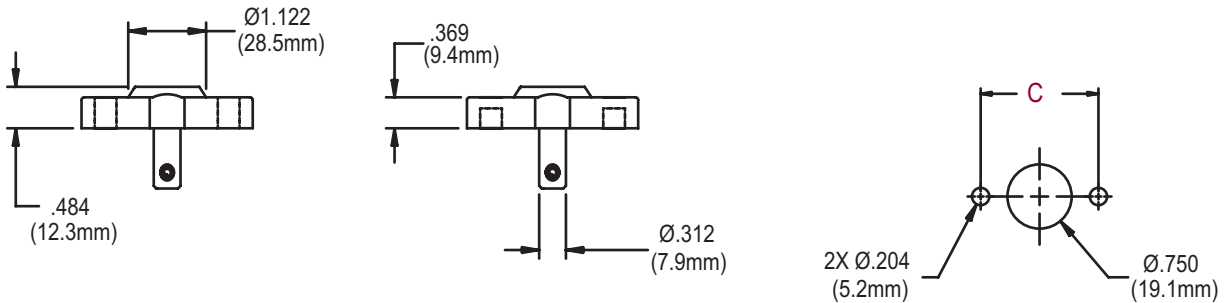

***RECOMMENDED SCREWS:**

WOOD/PVC/METAL:

FRONT MOUNT: 2 - #10-24 PHILLIPS, PAN HEAD, STAINLESS STEEL SCREWS (LENGTH AND THREAD TYPE TO BE DETERMINED BY PROFILE)

REAR MOUNT: 2 - #10-24 PHILLIPS, PAN HEAD, SELF TAPPING, STAINLESS STEEL SCREWS (LENGTH TO BE DETERMINED BY PROFILE)

LOCK CUT-OUT (BOTH TYPES)

PART NO.	A	B	C	MOUNTING	FORCED ENTRY RESISTANCE
28.23	.438 (11.1mm)	.218 (5.6mm)	1.500 (38.1mm)	REAR	300 LBS.
28.24	.438 (11.1mm)	.344 (8.7mm)	1.500 (38.1mm)	REAR	250 LBS.
28.26	.875 (22.2mm)	.218 (5.6mm)	1.500 (38.1mm)	REAR	300 LBS.
28.27	.875 (22.2mm)	.344 (8.7mm)	1.500 (38.1mm)	REAR	250 LBS.
28.29	.438 (11.1mm)	.218 (5.6mm)	1.375 - 1.500 (34.9mm-38.1mm) SLOTTED HOLES	FRONT	300 LBS.
28.31	.438 (11.1mm)	.562 (14.3mm)		FRONT	160 LBS.
28.32	.875 (22.2mm)	.218 (5.6mm)		FRONT	300 LBS.
28.34	.875 (22.2mm)	.562 (14.3mm)		FRONT	160 LBS.
28.66	.875 (22.2mm)	.938 (23.8mm)		FRONT	50 LBS.

FIG. 2 20303 AND 20404 KEEPERS

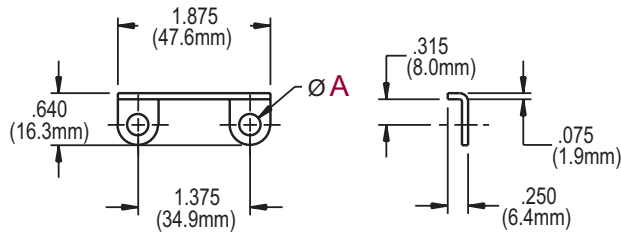

PART NO.	A DIA
20303	.204 (5.2mm)
20404	.250 (6.4mm)

RECOMMENDED SCREWS:

WOOD/PVC/METAL: 2 - #10 PHILLIPS, PAN HEAD, STAINLESS STEEL SCREWS (LENGTH AND THREAD TYPE TO BE DETERMINED BY PROFILE)

FIG. 3 30238 KEEPER

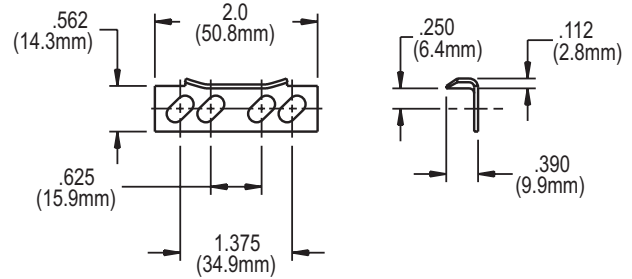

RECOMMENDED SCREWS:

WOOD/PVC/METAL: 2 - #10 PHILLIPS, PAN HEAD, STAINLESS STEEL SCREWS (LENGTH AND THREAD TYPE TO BE DETERMINED BY PROFILE)

FIG. 4 20313 KEY

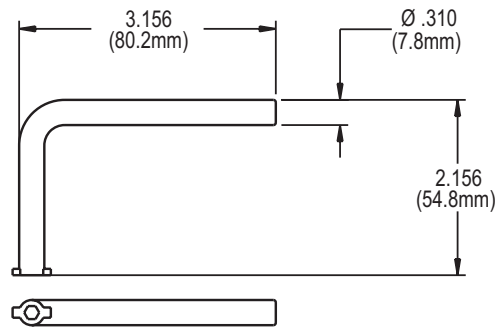

REMOVEABLE HANDLE



700 WEST BRIDGE STREET, OWATONNA, MN 55060 ■ 507.451.5620 800.866.7884 ■ TRUTH.COM